

CAIXA DE INSPEÇÃO - (CONCRETO PRÉ-MOLDADO)

OPÇÃO 2 - (CILÍNDRICA)

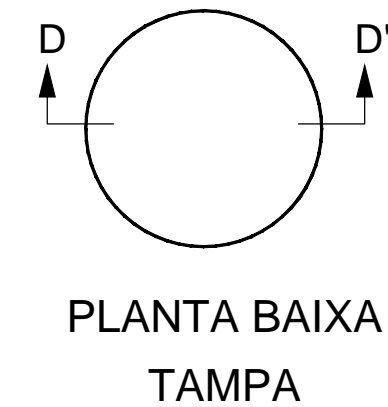
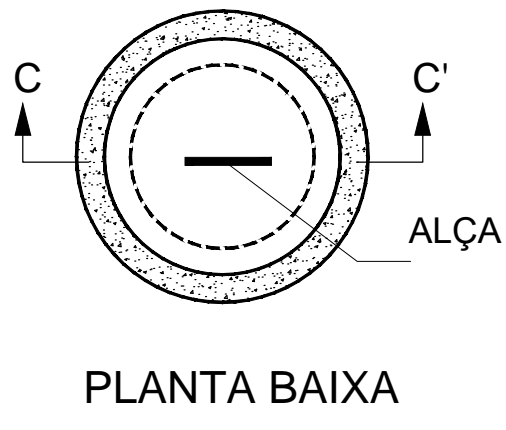
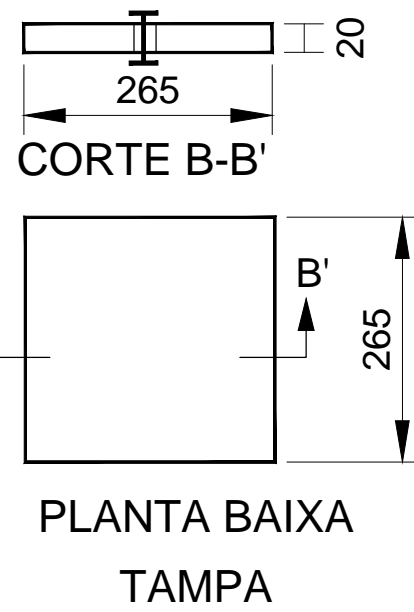
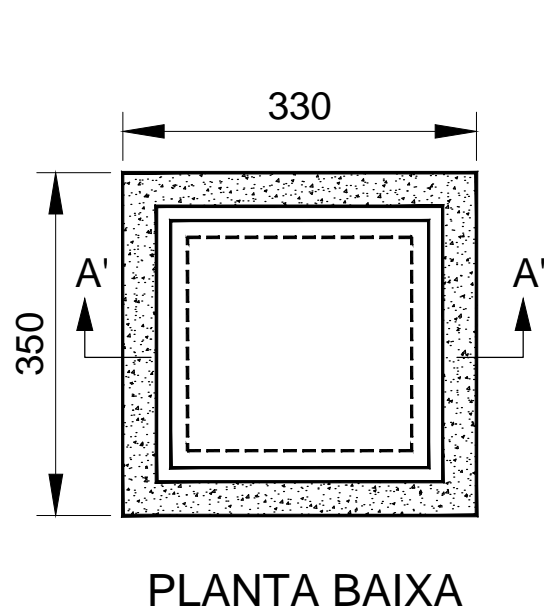
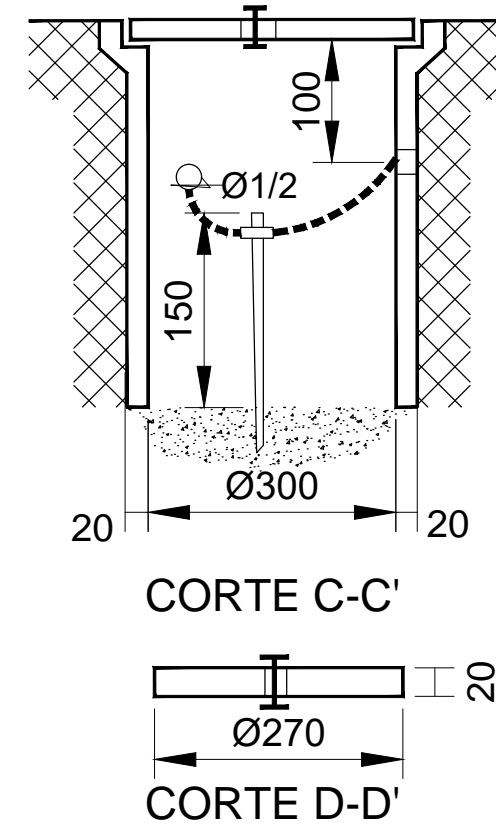
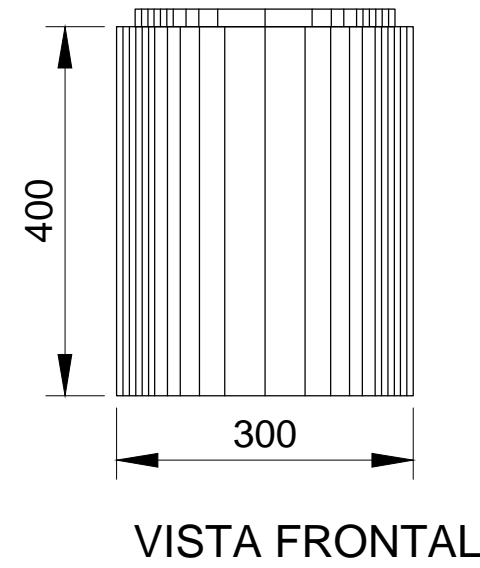
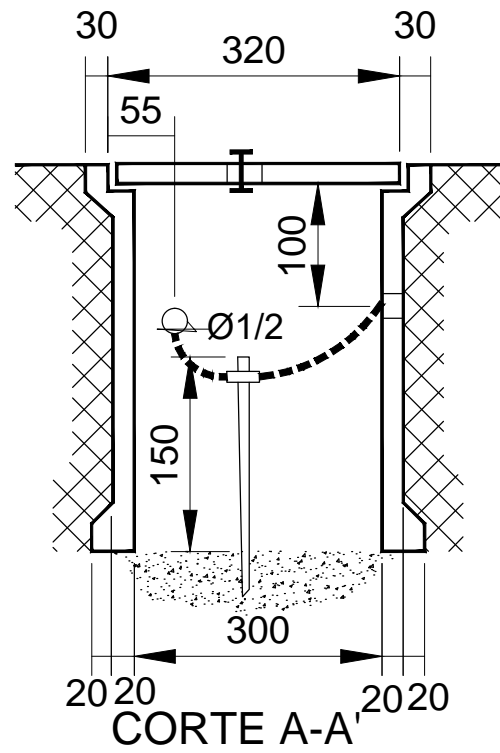
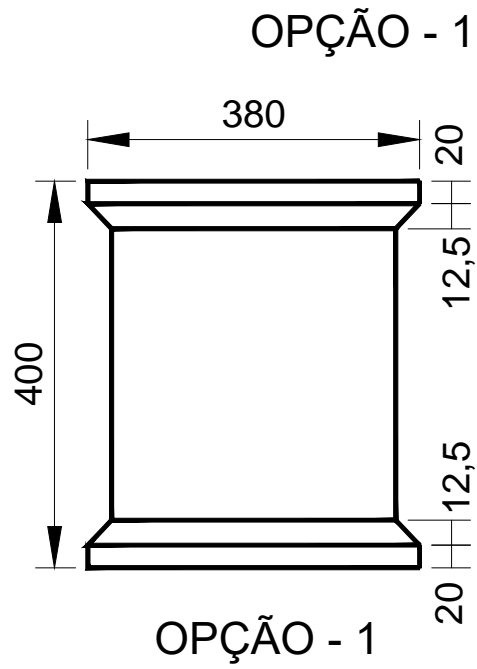

NOTA: DIMENSÕES EM MILÍMETROS (mm)

	PROJETO: SE 300KVA SUINOS	Prancha N° 08
	ENDEREÇO: LINHA PRATA N°: 00, INTERIOR, BANDEIRANTE - SC	Projeto N° 023
RESPONSÁVEL TÉCNICO	Luiz Fernando Vanzin Eng. Eletricista-CREA/SC 41297-4	
INTERESSADO	FRANCO LUIZ LAGEMANN CPF - 002.449.970-63	
PROJETA Cristiano Schneider	DIGITALIZAÇÃO	ESCALA SEM A-3
		DATA 20/04/2021